



AcousticDesign™ Series

AD-P4T-WH

AD-P4T-BK

Small format, pendant-mount
loudspeaker

Features

- Consistent tonal characteristics across the entire AcousticDesign family in surface, ceiling, and pendant applications
- DMT (Directivity Matched Transition™) waveguide ensures smooth, uniform frequency response over the coverage area
- Snap-fit magnetic grille
- 2x quick-link suspension cables and slip-lock fasteners provided
- Intrinsic Correction™ voicings available via Q-SYS Q-SYS Platform and CXD amplifiers
- Low-saturation and low-loss 70/100V transformers with 16Ω bypass
- Blemish-free removable logo
- Sealable input cover to prevent moisture from entering the input terminal block
- UL1480 certified EN54-24 Type A (pending)
- Available in black (RAL 9011) or white (RAL 9010)
- Complete EASE, CF2, CAD, & BIM information available online



Restaurant · Retail · Audio Visual · Education · Concourses · Casinos · Transportation Terminals · Worship Facilities · Large System Ancillary Support

The QSC AcousticDesign™ AD-P4T is a 4.5" two-way pendant-mount loudspeaker ideally suited for a wide variety of foreground and background sound reinforcement applications which utilize 70/100V or 16Ω bypass configurations.

The AcousticDesign™ Series offers integrators a premium quality installed sound solution where performance, consistent coverage, and aesthetics are paramount. Specifically designed to maintain a consistent tonal characteristic across the entire family in ceiling, surface, and pendant applications, the AcousticDesign series allows integrators seamless transitions within blended installations.

DMT (Directivity Matched Transition™) is QSC's design philosophy where the high frequency waveguide is matched to the natural conical behavior of the woofer at the crossover point. The result is a coherent transition between transducers with improved off-axis power response for consistent 150° conical DMT coverage.

The AD-P4T features a high quality 4.5" weather treated paper cone woofer with a 1" voice coil and a .075" aluminum dome tweeter positioned on a DMT waveguide.

The accurate frequency response of the AD-P4T is maintained even in 70/100V applications by use of a low-loss, low-saturation 30-watt transformer with selectable taps, including 16Ω bypass,

using a rotary selector located under the snap-fit magnetically attached powder coat steel grille.

To retain lasting good looks, the rugged ABS enclosure is further protected by using UV inhibitors that prevent discoloration. The magnetic grille features a stick-on logo that can be removed blemish-free for installations where branding is not permitted.

Installers will appreciate the two quick-link cable assemblies and slip-lock fasteners to speed the installation. Located under a sealable input cover to prevent moisture at the terminals, a locking 4-pole Euro-block connector that can accept four 18AWG pairs eliminates the termination hassles of star topology wiring designs.

To further speed the install process while obtaining optimal results, Intrinsic Correction™ voicings are easily deployed via Q-SYS Platform and CXD series amplifiers, as part of a complete QSC Systems solution.

The AD-P4T is available in QSC standard black (RAL 9011) or white (RAL 9010) and may be painted to match any decor.

For your system integration needs, complete EASE, CF2, CAD, and BIM files are available for download at QSC.com.

AD-P4T Details

Impedance / Frequency Response:

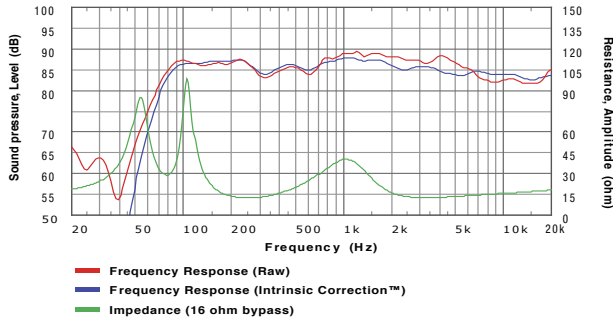

Beamwidth:

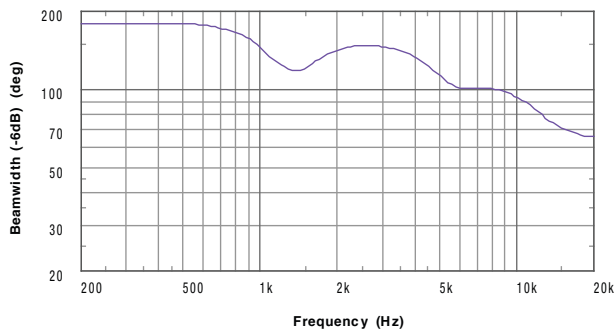

Dimensions:

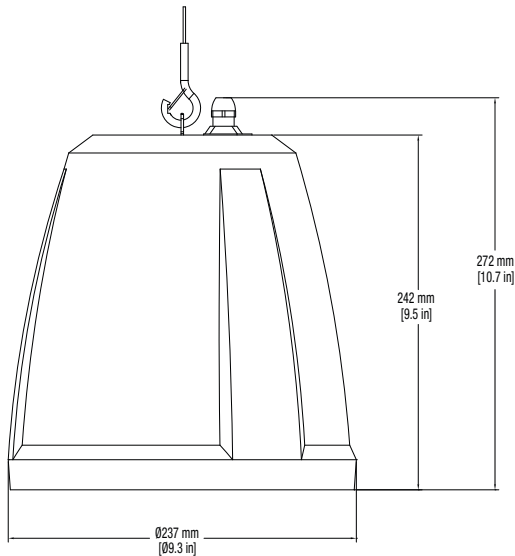

As part of QSC's ongoing commitment to product development, specifications are subject to change without notice.

Specifications

System Details	AD-P4T
Effective frequency range ¹	65 Hz – 20 kHz
Rated noise power / voltage ²	30 watts / 22 volts (rms)
Sensitivity [dB] ⁴	87.9
Sensitivity at 4m, 100V maximum tap	TBD
Rated coverage (-6 dB) ³	150° conical DMT™
Directivity factor ³	4.5
Directivity index [dB] ³	6.5
Maximum continuous SPL [dB] ⁵	102
Maximum peak SPL [dB] ⁵	108
Nominal impedance [ohms]	16
Recommended amplifier	60 watts
Transformer taps / impedance	16Ω (in bypass setting) 3.75W (70V); 7.5W (100V) Tap: 1333Ω 7.5W (70V); 15W (100V) Tap: 667Ω 15W (70V); 30W (100V) Tap: 333Ω 30W (70V); N/A (100V) Tap: 167Ω
LF transducer	114 mm [4.5 in] weather treated paper cone woofer
HF transducer	19 mm [0.75" in] aluminum dome tweeter
Input connector type	Euroblock connector with parallel output
Enclosure material	Flame retardant ABS 765A V0 baffle and back can
Grille material	Powder coated steel
Ingress protection	IP-34
Operating environment	Designed for indoor use
Operating temperature range	-20 to 50° C [-4 to 122° F]
Net weight	2.9 kg [6.5 lb]
Product dimensions (Diameter x Height)	Ø 237 x 272 mm [Ø 9.3 x 10.7 in.]
Shipping weight	3.9 kg [8.7 lb]
Shipping dimensions (H x W x D)	298 x 362 x 286 mm [11.75 x 14.25 x 11.25 in]
Included Mounting Hardware	Two quick-link cable assemblies (length 3.25m/128in 2mmthickness), two slip-lock fasteners, locking euro-block connector, sealable input cover and screws, snap-fit magnetic grille.
Safety Agency	UL1480, Transformer UL registered per UL1876, ROHS, C-Tick (pending), CE compliant. Baffle meets UL94-V0 and UL94-5VB flammability rating; in accordance with IEC60849 / EN60849 systems.

¹ IES60268-5 50 Hz high passed noise signal for 2 hr, 16 ohm

² -10dB from rated sensitivity

⁴ 500 Hz-5 kHz average

³ -6db from on-axis, 500Hz - 5kHz

⁵ Calculated from rated noise voltage and sensitivity

QSC®

1675 MacArthur Boulevard • Costa Mesa, CA 92626 • Ph: 800/854-4079 or 714/957-7100 • Fax: 714/754-6174

© 2017 QSC, LLC all rights reserved. QSC and the QSC logo are registered trademarks of QSC, LLC in the U.S. Patent and Trademark office and other countries. All other trademarks are the property of their respective owners. Patents may apply or be pending.

AD-P4T Spec Sheet 03/14/2017



please recycle